

## GF..00

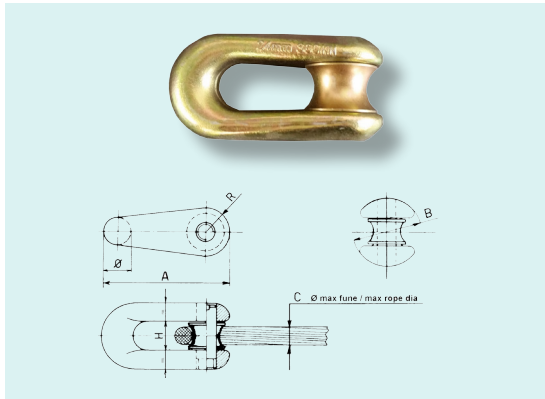

Joint made of high tensile galvanised steel, fit to connect pilot rope lengths and pulling rope. Designed to pass on the capstan grooves of pullers or puller/tensioners.

	Dimensions mm					for rope	W.L	Weight
	A	H	B	Ø	R	Ø mm	kN	kg
GF.10.00	68	14	36	17	13	10/12	23	0,20
GF.13.00	76	17	37	21	15	13/14	37	0,30
GF.16.00	96	19	50	22	20	16	53	0,60
GF.18.00	110	25	56	24	22	18/20	73	0,90
GF.24.00	125	26,5	60	28	24	22/24	120	1,30
GF.26.00	168	30	72	38	30	26/28	250	3,00
GF.32.00	178	35	80	44	34	28/32	280	3,50

## F250.R

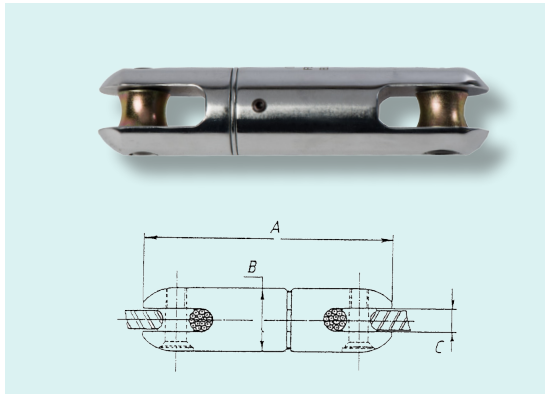

Swivel joint for ropes and conductors. Designed to release the torsion efforts during the pulling operations. Made of galvanised steel, complete with an axial bearing for an easy rotation.

	Dimensions mm			for rope	W.L	Weight
	A	B	C	Ø mm	kN	kg
F250.R.06.1	60	18	9	7	4	0,7
F250.R.08.1	96	24	12	9	8	0,10
F250.R.12.1	137	32	13	14	25	0,36
F250.R.13.1	152	39	17	16	40	0,90
F250.R.16.1	177	45	20	18	63	1,50
F250.R.18.1	182	52	22	22	80	2,30
F250.R.24.1	228	60	25	26	130	3,10
F250.R.28.1	322	77	31	32	260	7,00
F250.R.32.1	337	80	36	38	280	10,50

Dimensions and weights are without optional devices. All data may change without notice. Images and drawings are indicative only.